

## Product Features

- DC – 4 GHz
- +18 dBm P1dB at 1 GHz
- +34 dBm OIP3 at 1 GHz
- 22.1 dB Gain at 1 GHz
- 3.3 dB Noise Figure at 2 GHz
- Lead-free / green SOT-89 pkg
- Internally matched to 50 Ω

## Applications

- Mobile Infrastructure
- CATV / DBS
- W-LAN / ISM
- RFID
- Defense / Homeland Security
- Fixed Wireless

## Product Description

The ECG005 is a general-purpose buffer amplifier that offers high dynamic range in a low-cost surface-mount package. At 1000 MHz, the ECG005 typically provides 22.1 dB of gain, +34 dBm Output IP3, and +18 dBm P1dB.

The ECG005 consists of Darlington pair amplifiers using the high reliability InGaP/GaAs HBT process technology and only requires DC-blocking capacitors, a bias resistor, and an inductive RF choke for operation. The device is ideal for wireless applications and is available in a low-cost, surface-mountable lead-free/green/RoHS-compliant SOT-89 package. All devices are 100% RF and DC tested.

The broadband MMIC amplifier can be directly applied to various current and next generation wireless technologies such as GPRS, GSM, CDMA, and W-CDMA. In addition, the ECG005 will work for other various applications within the DC to 4 GHz frequency range such as CATV and fixed wireless.

## Functional Diagram

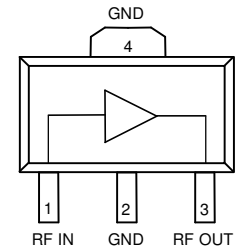

Function	Pin No.
Input	1
Output/Bias	3
Ground	2, 4

## Specifications <sup>(1)</sup>

Parameter	Units	Min	Typ	Max
Operational Bandwidth	MHz	DC		4000
Test Frequency	MHz		1000	
Gain	dB		22.1	
Output P1dB	dBm		+18	
Output IP3 <sup>(2)</sup>	dBm		+34	
Test Frequency	MHz		2000	
Gain	dB	19.8	21.4	22.8
Input Return Loss	dB		19	
Output Return Loss	dB		11	
Output P1dB	dBm	+16.5	+17.5	
Output IP3 <sup>(2)</sup>	dBm	+30	+32	
Noise Figure	dB		3.3	
Device Voltage	V	4.2	4.8	5.3
Device Current	mA		65	

1. Test conditions unless otherwise noted: 25° C, Supply Voltage = +6 V, R<sub>bias</sub> = 18 Ω, 50 Ω System.  
 2. 3OIP measured with two tones at an output power of +4 dBm/tone separated by 1 MHz. The suppression on the largest IM3 product is used to calculate the 3OIP using a 2:1 rule.

## Typical Performance <sup>(3)</sup>

Parameter	Units	Typical			
Frequency	MHz	500	900	1900	2140
S21	dB	22.4	22.2	21.5	21.3
S11	dB	-28	-25	-20	-18
S22	dB	-22	-18	-11	-10
Output P1dB	dBm	+17.8	+18	+17.5	+19.0
Output IP3	dBm	+33	+34	+32	+30.5
Noise Figure	dB	5.2	3.4	3.3	3.8

3. Test conditions: T = 25° C, Supply Voltage = +6 V, Device Voltage = +4.8V, R<sub>bias</sub> = 18 Ω, 50 Ω System.

## Absolute Maximum Rating

Parameter	Rating
Operating Case Temperature	-40 to +85 °C
Storage Temperature	-55 to +150 °C
Device Current	130 mA
RF Input Power (continuous)	+12 dBm
Junction Temperature	+250° C

Operation of this device above any of these parameters may cause permanent damage.

## Ordering Information

Part No.	Description
ECG005B <sup>(4)</sup>	InGaP HBT Gain Block (lead SOT-89 Pkg)
ECG005B-G	InGaP HBT Gain Block (lead-free/green/RoHS-compliant SOT-89 Pkg)
ECG005C <sup>(5)</sup>	InGaP HBT Gain Block (lead-tin SOT-86 Pkg)
ECG005B-PCB	700 –2400 MHz Fully Assembled Eval. Board

4. This package is being phased out in favor of the green package type which is backward compatible for existing designs. Refer to Product Change Notification WJPCN06MAY05TC1 on the WJ website.  
 5. This package style is not recommended for new designs. Refer to Product Obsolescence Notification WJOBS22APR05TC1. The ECG005B-G or AG604-86G is recommended as a suitable replacement.

Specifications and information are subject to change without notice



## Typical Device RF Performance

Supply Bias = +6 V,  $R_{bias} = 18 \Omega$ ,  $I_{cc} = 65 \text{ mA}$

Frequency	MHz	100	500	900	1900	2140	2400	3500	5800
S21	dB	22.5	22.5	22.2	21.5	21.3	21.1	20.2	17.2
S11	dB	-29.5	-28	-25	-19.5	-18	-16.9	-14.2	-8.2
S22	dB	-31	-22	-17.5	-11.2	-10.3	-9.5	-6.7	-3
Output P1dB	dBm	+17.5	+17.8	+18	+17.6	+17.3	+17.1	+16	
Output IP3	dBm	+33.6	+33.5	+34	+32	+31.5	+31		
Noise Figure	dB	5.4	5.3	3.5	3.3	3.3	3.3		

1. Test conditions: T = 25°C, Supply Voltage = +6 V, Device Voltage = 4.8 V,  $R_{bias} = 18 \Omega$ ,  $I_{cc} = 65 \text{ mA}$  typical, 50  $\Omega$  System.
2. 3OIP measured with two tones at an output power of +4.5 dBm/tone separated by 1 MHz. The suppression on the largest IM3 product is used to calculate the 3OIP using a 2:1 rule.
3. Data is shown as device performance only. Actual implementation for the desired frequency band will be determined by external components shown in the application circuit.

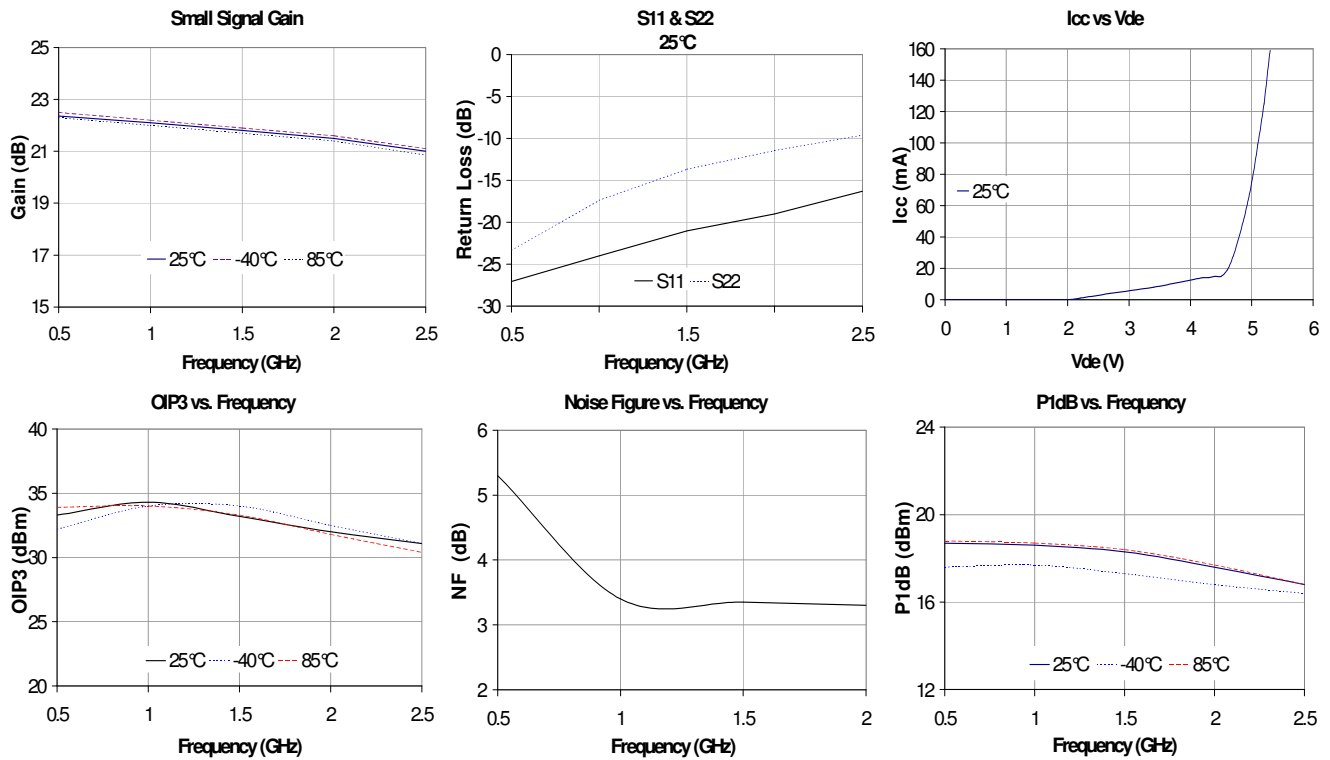



## Recommended Application Circuit (ECG005B-PCB)

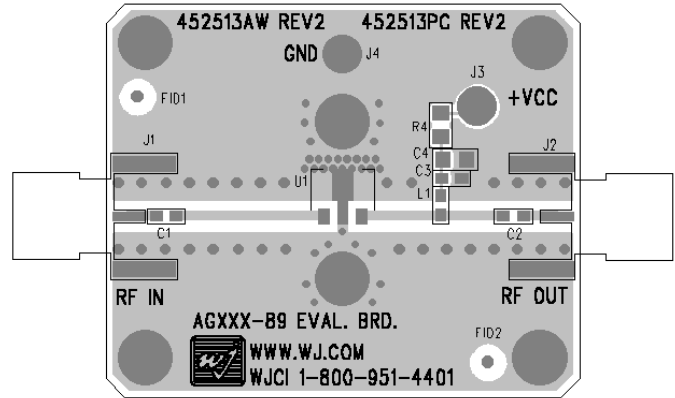
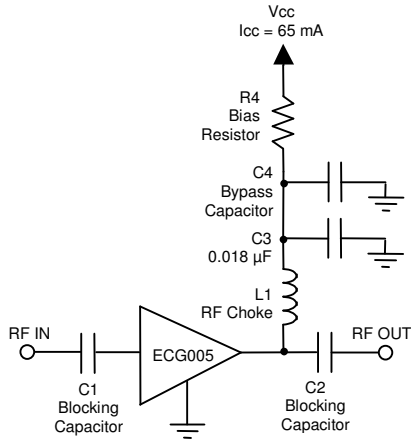

Recommended Component Values

Reference Designator	Frequency (MHz)						
	50	500	900	1900	2200	2500	3500
L1	820 nH	220 nH	68 nH	27 nH	22 nH	18 nH	15 nH
C1, C2, C4	.018 µF	1000 pF	100 pF	68 pF	68 pF	56 pF	39 pF

- The proper values for the components are dependent upon the intended frequency of operation.
- The following values are contained on the evaluation board to achieve optimal broadband performance:

Ref. Desig.	Value / Type	Size
L1	39 nH wirewound inductor	0603
C1, C2	56 pF chip capacitor	0603
C3	0.018 µF chip capacitor	0603
C4	Do Not Place	
R4	18 Ω 1% tolerance	0805

Recommended Bias Resistor Values

Supply Voltage	R1 value	Size
6 V	18.5 ohms	0805
7 V	33.8 ohms	1210
8 V	49 ohms	1210
9 V	65 ohms	2010
10 V	80 ohms	2010
12 V	111 ohms	2512

The proper value for R1 is dependent upon the supply voltage and allows for bias stability over temperature. WJ recommends a minimum supply bias of +6 V. A 1% tolerance resistor is recommended.



## ECG005B (SOT-89 Package) Mechanical Information

This package may contain lead-bearing materials. The plating material on the leads is SnPb.

### Outline Drawing

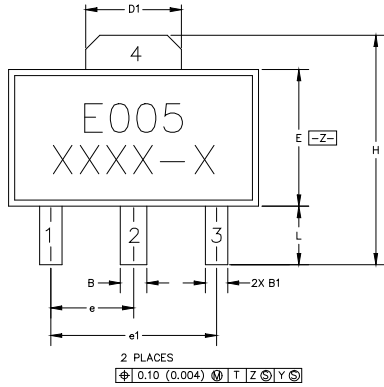

SYMBOL	MIN	MAX
A	1.40 (.055)	1.60 (.063)
B	.44 (.017)	.56 (.022)
B1	.36 (.014)	.48 (.019)
C	.35 (.014)	.44 (.017)
D	4.40 (.173)	4.60 (.181)
D1	1.62 (.064)	1.83 (.072)
E	2.29 (.079)	2.60 (.102)
E1	2.13 (.084)	2.29 (.090)
e	1.50 BSC (.059)	
e1	3.00 BSC (.118)	
H	3.94 (.155)	4.25 (.167)
L	.89 (.035)	1.04 (.041)
M	4.04 (.159)	4.19 (.164)

- NOTES:
1. DIMENSIONS CONFORM WITH JEDEC TO-243C EXCEPT WHERE INDICATED.
  2. DIMENSIONS ARE EXPRESSED IN MILLIMETER.
  3. DIMENSIONING AND TOLERANCING IAW ANSI Y14.5M-2009.

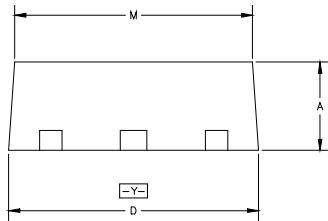

### Product Marking

The component will be marked with an "E005" designation with an alphanumeric code on the top surface of the package.

Tape reel specifications for this part are located in the Application Note section.

### Moisture / ESD Rating

Caution: ESD sensitive device.

- Moisture Rating: 1A
- Storage: 25 to 50°C (77 to 122°F)
- Test: Human Body Model (HBM)
- Standard: JEDEC Standard JESD22-A114

- MSL Rating: Level 3 at +235°C convection reflow
- Standard: JEDEC Standard J-STD-020

### Land Pattern

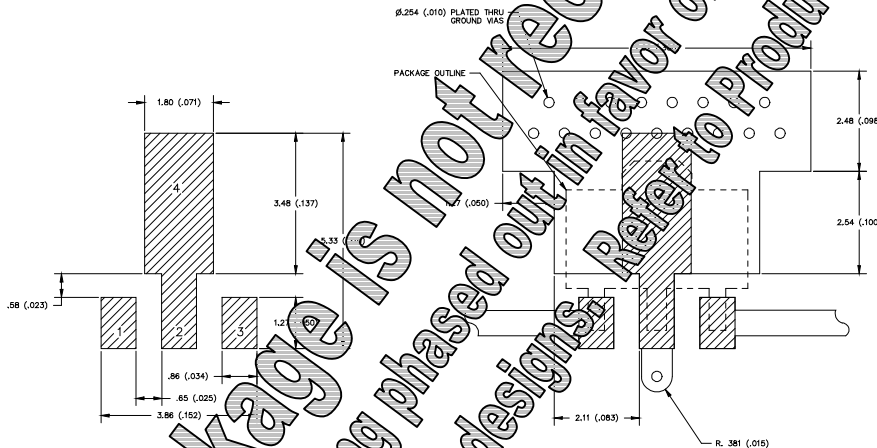

### Mounting Config. Notes

1. Ground / thermal vias are critical for the proper performance of this device. Vias should use a .35mm (#80 / .0135") diameter drill and have a final plated thru diameter of .25 mm (.010").
2. Add as much copper as possible to inner and outer layers near the part to ensure optimal thermal performance.
3. Mounting screws can be added near the part to fasten the board to a heatsink. Ensure that the ground / thermal via region contacts the heatsink.
4. Do not put solder mask on the backside of the PC board in the region where the board contacts the heatsink.
5. RF trace width depends upon the PC board material and construction.
6. Use 1 oz. Copper minimum.
7. All dimensions are in millimeters (inches). Angles are in degrees.

## ECG001B-G (Green / Lead-free SOT-89 Package) Mechanical Information

This package is lead-free/Green/RoHS-compliant. It is compatible with both lead-free (maximum 260°C reflow temperature) and leaded (maximum 245°C reflow temperature) soldering processes. The plating material on the leads is NiPdAu.

### Outline Drawing

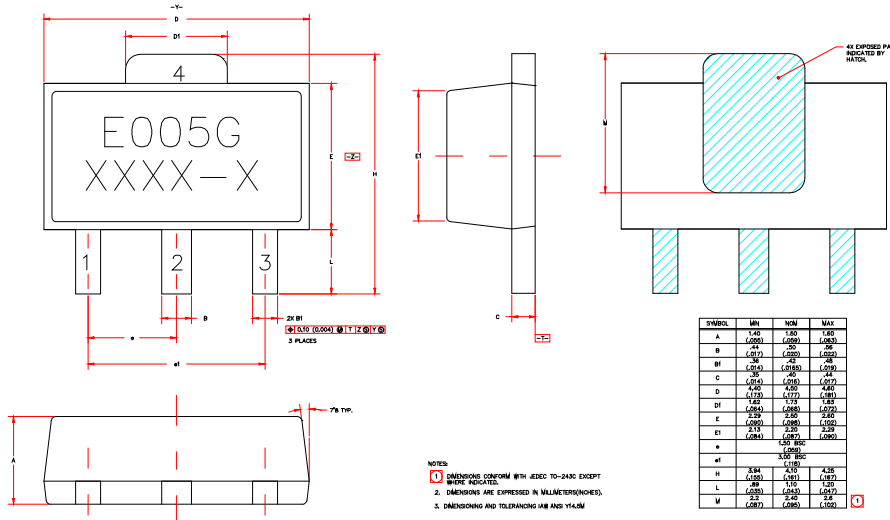

### Product Marking

The component will be marked with an "E005G" designator with an alphanumeric lot code on the top surface of the package.

Tape and reel specifications for this part are located on the website in the "Application Notes" section.

### MSL / ESD Rating



Caution! ESD sensitive device.

ESD Rating: Class 1A  
 Value: Passes between 250 and 500V  
 Test: Human Body Model (HBM)  
 Standard: JEDEC Standard JESD22-A114

MSL Rating: Level 3 at +260° C convection reflow  
 Standard: JEDEC Standard J-STD-020

### Land Pattern

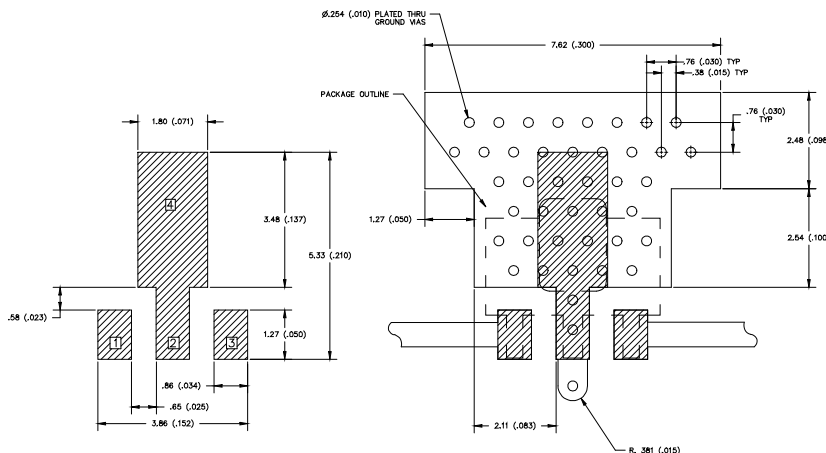

### Mounting Config. Notes

1. Ground / thermal vias are critical for the proper performance of this device. Vias should use a .35mm (#80 / .0135") diameter drill and have a final plated thru diameter of .25 mm (.010").
2. Add as much copper as possible to inner and outer layers near the part to ensure optimal thermal performance.
3. Mounting screws can be added near the part to fasten the board to a heatsink. Ensure that the ground / thermal via region contacts the heatsink.
4. Do not put solder mask on the backside of the PC board in the region where the board contacts the heatsink.
5. RF trace width depends upon the PC board material and construction.
6. Use 1 oz. Copper minimum.
7. All dimensions are in millimeters (inches). Angles are in degrees.



**ECG005C (SOT-86 Package) Mechanical Information**

**Outline Drawing**

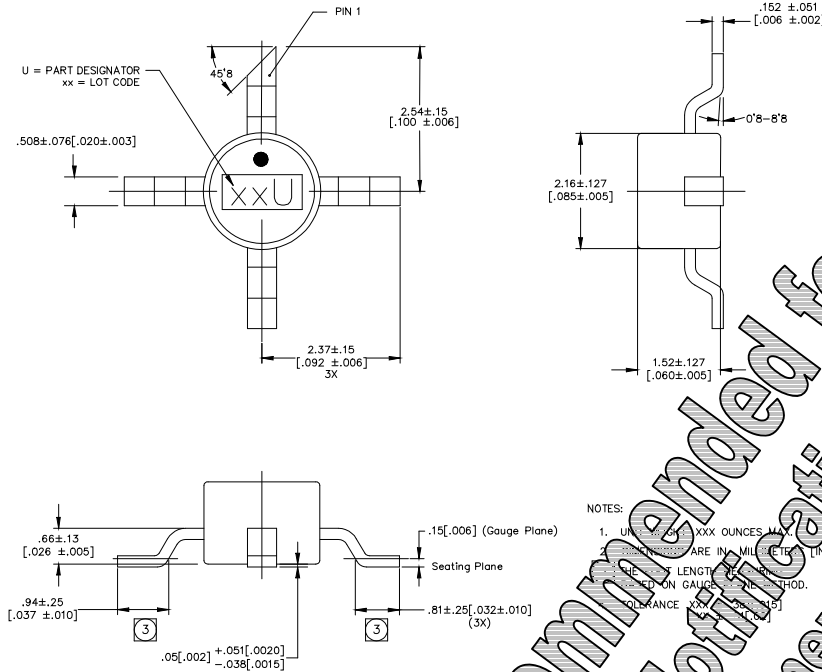

**Product Marking**

The component will be marked with a two-digit number, lot code, followed by a "U" designator on the top surface of the package.

For more information on this part are available on the website under the "Application Notes" section.

**MIL-STD Rating**

Warning! ESD sensitive device.

ESD Rating: Class 1A  
Value: Passes between 250 and 500V  
Test Method: Human Body Model (HBM)  
Standard: JEDEC Standard JESD22-A114

MIL Rating: Level 1 at +235° C convection reflow  
Standard: JEDEC Standard J-STD-020

**Land Pattern**

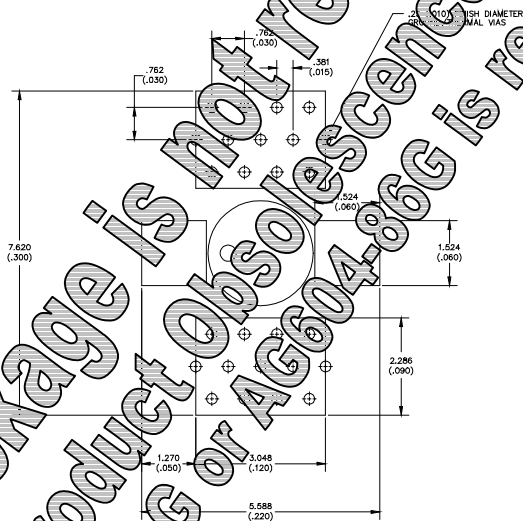

**Mounting Config. Notes**

1. Ground / thermal vias are critical for the proper performance of this device. Vias should use a .35mm (#80 / .0135") diameter drill and have a final plated thru diameter of .25 mm (.010").
2. Add as much copper as possible to inner and outer layers near the part to ensure optimal thermal performance.
3. Mounting screws can be added near the part to fasten the board to a heatsink. Ensure that the ground / thermal via region contacts the heatsink.
4. Do not put solder mask on the backside of the PC board in the region where the board contacts the heatsink.
5. RF trace width depends upon the PC board material and construction.
6. Use 1 oz. Copper minimum.
7. All dimensions are in millimeters (inches). Angles are in degrees.



## Typical Device S-Parameters – ECG005B / ECG005B-G

S-Parameters ( $V_{\text{device}} = +4.8 \text{ V}$ ,  $I_{\text{CC}} = 65 \text{ mA}$ ,  $T = 25^\circ\text{C}$ , calibrated to device leads)

Freq (MHz)	S11 (dB)	S11 (ang)	S21 (dB)	S21 (ang)	S12 (dB)	S12 (ang)	S22 (dB)	S22 (ang)
50	-33.81	-161.46	22.53	177.86	-24.24	0.19	-29.52	-10.77
500	-34.12	-135.89	22.36	159.30	-24.29	-5.13	-21.96	-80.32
1000	-25.88	-122.57	22.10	138.63	-23.67	-9.76	-16.38	-110.06
1500	-21.94	-136.54	21.80	119.41	-23.50	-15.45	-13.06	-132.72
2000	-19.63	-145.42	21.49	99.88	-23.04	-19.26	-10.90	-153.43
2500	-16.68	-165.15	21.20	80.49	-22.91	-25.61	-9.14	-172.26
3000	-15.77	177.44	20.74	61.36	-22.48	-34.76	-7.57	170.00
3500	-14.11	162.19	20.26	42.76	-21.95	-42.47	-6.61	150.90
4000	-12.65	141.66	19.76	23.27	-21.02	-51.88	-5.50	133.37
4500	-11.49	120.75	19.19	4.28	-21.18	-58.92	-4.66	115.20
5000	-9.97	99.89	18.51	-15.13	-20.97	-70.63	-4.16	94.80
5500	-8.98	80.49	17.58	-33.50	-20.43	-80.16	-3.60	77.20
6000	-8.12	62.50	16.79	-51.89	-20.38	-94.99	-3.03	60.86

## Typical Device S-Parameters – ECG005C

S-Parameters ( $V_{\text{device}} = +4.8 \text{ V}$ ,  $I_{\text{CC}} = 65 \text{ mA}$ ,  $T = 25^\circ\text{C}$ , calibrated to device leads)

Freq (MHz)	S11 (dB)	S11 (ang)	S21 (dB)	S21 (ang)	S12 (dB)	S12 (ang)	S22 (dB)	S22 (ang)
50	-27.31	-170.67	22.49	178.07	-24.27	-0.70	-36.78	-43.46
500	-27.05	-164.65	22.35	159.35	-24.09	-3.90	-23.35	-97.68
1000	-23.98	-146.95	22.11	138.58	-23.84	-10.24	-17.38	-118.47
1500	-21.03	-151.50	21.80	119.17	-23.50	-14.72	-13.68	-139.78
2000	-19.01	-154.84	21.49	99.87	-23.31	-21.42	-11.45	-158.22
2500	-16.31	-170.67	21.18	80.41	-22.99	-28.29	-9.62	-175.54
3000	-15.21	175.52	20.76	61.25	-22.30	-35.25	-7.83	166.99
3500	-14.01	161.09	20.28	42.66	-22.29	-44.75	-6.92	148.94
4000	-12.70	140.82	19.82	23.32	-21.66	-52.82	-5.73	130.67
4500	-11.51	123.35	19.26	4.03	-20.63	-61.88	-4.80	114.02
5000	-10.11	102.11	18.68	-15.00	-21.12	-72.81	-4.36	93.63
5500	-9.31	80.29	17.78	-33.89	-20.33	-82.34	-3.70	76.68
6000	-8.20	62.93	17.06	-52.32	-20.32	-95.93	-3.02	60.47

Device S-parameters are available for download off of the website at: <http://www.wj.com>